

Evaluating the Impact of Strategic Sustainable Orientation and Socioeconomic Policies on the Mining Sector in Ghana

Charles Randy Afful
Tomas Bata University, Zlin,
Czechia
afful@utb.cz
 0009-0005-8787-9883

Aloysius Sabog
Tomas Bata University, Zlin,
Czechia
sabog@utb.cz
 0009-0003-5216-7304

Matthew Amoako
Kwame Nkrumah University of
Science and Technology, Kumasi,
Ghana
matthew.amaoko@knust.edu.gh
 0000-0002-7817-6474

ABSTRACT

Research background: The ongoing environmental and socio-economic impacts of mining activities have undermined community acceptance of mining firms. Long-term dissatisfaction with firms' operations has contributed to illegal practices and to demands for benefits beyond those provided through corporate social responsibility initiatives. As stakeholder pressure for responsible mining increases, firms are increasingly expected to implement sustainable and socio-economic measures that promote the development of host communities and enhance community satisfaction.

Purpose of the article: This study investigates the effects of strategic sustainable orientation and socio-economic factors on community satisfaction with mining in Ghana. Drawing on local content policy theory and stakeholder theory, the study employs partial least squares structural equation modelling (PLS-SEM) to address prevailing misconceptions in this area.

Methods: The study adopted a quantitative design and collected data from 232 community members using closed-ended questionnaires. Respondents were selected through purposive sampling, and questionnaires were administered via personal contacts. The data were analysed using PLS-SEM. Measurement quality was assessed using reliability and validity indicators, multicollinearity diagnostics, discriminant validity, and the Fornell–Larcker criterion.

Findings & Value added: The results indicate that community satisfaction depends significantly on mining firms' strategic sustainable orientation practices and the socio-economic policies they implement. In addition, socio-economic factors mediate the relationship between sustainable orientation and community satisfaction. Finally, the findings suggest that, to address research and empirical gaps in Ghana's mining sector, firms should enhance community satisfaction by implementing sustainability-oriented practices and socio-economic policies. This study contributes to the literature on mining in Africa, and its implications may be generalisable to other mining contexts.

RECEIVED: December 17 2025 © **ACCEPTED:** February 26 © **PUBLISHED ONLINE:** June 30

KEYWORDS: community satisfaction, local content policy, mining sector, socioeconomic, stakeholder theory, sustainable orientation

JEL CLASSIFICATION: Q53, L71, O13, O25

CITATION: Afful, Ch. R., Sabog, A. & Amoako, M. (2026). Evaluating the Impact of Strategic Sustainable Orientation and Socioeconomic Policies on the Mining Sector in Ghana. *Journal of Business Sectors*, 4(1), 43–56. <https://doi.org/10.62222/YEBO6947>

INTRODUCTION

The promotion of sustainable cities and communities under SDG 11 requires safeguarding natural resources and calls for pragmatic, country-level policies that adopt sustainable strategies (Yu et al., 2023). Improving communities' socio-economic livelihoods will support the attainment of SDGs 3, 6, 8, 10, 11, and 15. Accordingly, this study is important for determining how sustainability-oriented strategies and socio-economic impacts influence community satisfaction in mining areas in Ghana.

Mining has been defined as the extraction of valuable geological resources by enabling access to minerals located beneath the earth's surface using appropriate technology, thereby potentially supporting infrastructure development (Kaksonen & Petersen, 2022). Mining methods include prospecting, extraction, and reclamation, and operations may be conducted through surface, underground, or placer mining (Upadhyay, 2025). The contribution of mining to economic recovery—through increased foreign direct investment, employment, and infrastructure development—can be substantial. However,

failures to reinvest benefits in affected communities have generated social discontent and inequitable resource allocation, particularly in communities directly impacted by mining firms' operations (Bjornlund et al., 2022), thereby increasing dissatisfaction with mining firms. This has prompted several African countries to consider revising long-standing mining legislation to secure greater benefits and to counter the notion of a "resource curse." For years, the development and livelihoods of these communities have been deprioritised, while they bear the adverse effects of mining on their well-being. Currently, resource-rich countries are striving to achieve economic growth while simultaneously fostering sustainable livelihoods and other socio-economic outcomes (Boateng et al., 2025).

The 2025 World Economic Forum report states that the discovery, extraction, processing, and utilisation of critical minerals raise complex economic, social, and environmental challenges, which may be exacerbated by insufficient international cooperation and weak multilateral frameworks (Vivoda et al., 2025). However, limited research has examined how sustainable orientation and socio-economic impacts of mining affect community satisfaction and livelihoods (Haroon & Hayyat, 2025). Prior research adopting a community-centred approach to assess social sustainability in mining communities in Zambia was constrained by its context specificity and by the omission of several sustainability dimensions; therefore, further studies in diverse settings and more holistic assessments are recommended (Kourouma et al., 2023). Mining communities also face rising health risks, including chemical poisoning and the loss of aquatic life (Adusei et al., 2025), pollution of agricultural products through contaminated water (Obiri-Yeboah et al., 2021), increased incidence of birth defects, widening poverty gaps, degradation of farmlands, and growing insecurity. These conditions necessitate research that balances economic activity with environmental protection to prevent further degradation of ecosystems. Recent advances in mining disclosure, including global standards introduced by the International Sustainability Standards Board (ISSB) and the European Union's European Sustainability Reporting Standards (ESRS), aim to strengthen transparency, accountability, and sustainability; however, environmental degradation and its implications for food security and socio-economic outcomes remain insufficiently addressed, indicating the need for strategic policies focused on food security and sustainability practices (Blanco et al., 2023).

In addition, corporate social responsibility (CSR) compliance is typically voluntary rather than legally binding, allowing firms to determine the scope of their community support (Kulkarni & Aggarwal, 2024). Consequently, CSR has not consistently produced the expected socio-economic benefits for communities. The absence of institutional guidelines governing CSR implementation (Dawar & Singh, 2023) may further undermine community acceptance of mining firms, given the limited impact of CSR activities on community satisfaction.

Although UNDP has developed the Human Development Index (HDI) and encourages countries to improve their performance, the HDI does not capture the specific impacts of mining on community satisfaction and individual well-being. There is therefore an urgent need to reassess the sustainable orientation and socio-economic impacts of mining operations on community satisfaction. Inadequate management of sustainability-oriented strategies and socio-economic plans in mining areas has deprived many residents of economic livelihoods and widened socio-economic disparities. Growing dissatisfaction with mining firms' contributions to socio-economic development and sustainability is also driving some youth into illegal mining as they attempt to compete with registered firms for resources (Asuamah Yeboah, 2023). Addressing community satisfaction may therefore require a sustainability and socio-economic framework grounded in local content policy and stakeholder theory. There have also been reports of forced incursions and illegal operations on some mining concessions, leading to violent confrontations and fatalities (Bansah et al., 2022).

These conflicts are largely driven by demands for a more equitable distribution of mining benefits and greater economic empowerment of local residents, particularly amid rising living costs and persistent impoverishment. Where communities' socio-economic development is prioritised, residents may even act as guardians of company resources (Sutrisno et al., 2024). Existing literature also emphasises that ensuring environmental stewardship and efficient resource use is a shared responsibility among stakeholders (Li et al., 2023). Given mining's multi-dimensional effects, a holistic assessment is warranted, with particular attention to socio-economic impacts and the effects of sustainable orientation on community satisfaction. This study is motivated by the need to evaluate the economic impacts of mining on community satisfaction, examine how leaders' strategic sustainable orientation influences community acceptance, assess current mining practices and their longer-term implications for extractive firms, and analyse the social impacts of mining on community livelihoods.

The empirical challenge motivating this research is the widening poverty gap in mining communities (Coulibaly et al., 2024), poor road networks, unemployment, high living costs, polluted environments, and heavy reliance on expatriate employees to operate mines in Ghanaian communities (Akuaake, 2024). The dilemma of natural resources constituting a curse rather than a blessing persists until mining produces tangible improvements in local livelihoods.

To develop a clearer understanding of these dynamics, this study evaluates whether existing strategic sustainable orientation policies and socio-economic practices influence community development and shape prospects for future mining exploration, using an overview of the Ewoyaa lithium project in Ghana. The study is guided by the following research questions: To what extent does leaders' sustainable orientation in mining influence community development? Do current mining practices identify

and address communities' socio-economic challenges? Do current exploration practices meet international standards for community development? Accordingly, the study's primary objective is to examine the effects of strategic sustainable orientation and socio-economic policies on future mining exploration and community attitudes.

Although lithium has been identified in commercial quantities in Ghana—adding to other mineral resources such as gold, diamond, bauxite, magnesium, limestone, and iron—it is in high demand for battery production and is central to the energy transition. However, the management of Ghana's mineral resources has not consistently improved community livelihoods; consequently, stakeholders often perceive that lithium mining may further harm rather than enhance local well-being. Concerns include high water use, toxic waste discharge, CO₂ emissions, and the reinforcement of global inequalities along racial and class lines (Dowling & Otero, 2025). Haroon and Hayyat (2025) report that community surveys indicate discontent with mining companies' practices, particularly inadequate CSR and insufficient attention to environmental and social consequences for affected communities. Amid increasing environmental awareness, firms have expanded the use of carbon credits as part of broader efforts to reduce climate-related impacts and demonstrate environmental responsibility.

Mining in Ghana dates to the nineteenth century, with early activity reported in 1821. Nevertheless, peripheral mining communities have derived limited benefits over time, contributing to disaffection, conflict, and poverty (Saaka, 2022; Valenzuela, 2020). Shiquan et al. (2022) report that mining exacerbated poverty in affected Ghanaian communities by 33.9%, alongside an 18.5% reduction in income and a 13.6% decline in health among neighbouring communities. These persistent challenges in Ghana's mining sector risk intensifying conflict in peripheral communities and undermining confidence in future exploration elsewhere. Despite the government's continued emphasis on mining's importance to the national economy, stakeholders' concerns regarding mining's impacts remain inadequately addressed (Ayambire et al., 2024; Tioluwani, 2023). Community leaders have also argued that government interest in natural resource extraction primarily serves national budget needs and development in other regions—particularly the capital—at the expense of mining communities that bear the negative impacts (Sefa-Nyarko, 2024). Sutrisno et al. (2024) further indicate that companies should adopt comprehensive sustainability reporting that covers CSR processes, community engagement, and post-mining environmental management, supported by appropriate documentation.

Consequently, communities have opposed the entry of new mining companies and, in some cases, requested direct negotiations on royalties, even where firms have legal concessions. This reflects perceived deficiencies in the government's socio-economic assessment of mining's impacts and in corrective measures that could support development and economic empowerment. Mo-

reover, Worlanyo et al. (2022) note that persistently low compensation to farmers for crops and land contributes to illegal mining participation, particularly in contexts where sustainable employment is limited and living costs continue to rise.

Many developing countries rely on extensive natural resource endowments for economic growth and transformation (Kwakwa et al., 2022), particularly minerals, oil, forests, and marine resources. However, evidence suggests that high poverty levels persist in mining communities and remain difficult to eradicate (Yan et al., 2024). Ghana's mineral revenue increased from 13.025 billion cedis in 2022 to 13.967 billion cedis in 2023, representing 7.2% of GDP; nevertheless, these gains have not translated into commensurate improvements in the livelihoods of people living in mining catchment areas.

The paper is organised as follows. Section 2 discusses the theoretical relationships underpinning the study. Section 3 reviews the literature on factors influencing environmental and economic sustainability and leaders' orientation, followed by the development of hypotheses. Section 4 presents the methodology, sampling procedures, and reliability testing. Section 5 reports the results and discusses the findings and conclusions. Section 6 outlines the implications and limitations.

THEORETICAL BACKGROUND

Various studies have been conducted on mining using some theoretical arguments, especially the resource-based view; however, this research will be grounded on the Local Content Policy (LCP) and the Stakeholder Theories (ST)

From the perspective of the LCP, mining firms should be able to maximise the benefits of natural resource extraction on local community economic development. It further recommends that a significant portion of the value generated from mining should remain in the local community and the country's development, ensuring employment opportunities, local procurement, building local capacities, ensuring technology transfer, and economic diversification of the local economy from its former status to ensure economic empowerment.

The communities' Sustainable resources must be protected with a strategic sustainable orientation (SSO) policy, which, through LCP, ensures that the community flora and fauna are protected from degradation to continuously provide farming support for community members who are not interested in working for the mining firms. Thus, stakeholders during negotiation must seek the well-being of the community through the local content policy theory to financially and economically empower the youth in the community, rather than neglecting them and promising them jobs when they have no expertise to be employed in the firm. This creates community disaffection between the firms and the community. The absence of socio-economic development creates stakeholder tension, which influences community aggression against firms. The im-

plementation of local content policy theory ensures community cordiality and improved firm community relationships. The notion has the potential of bringing mining gains to the local community. It has been criticised for its potential to induce trade-off conflicts between businesses and the community, economic distortions, particularly when local procurement prices exceed market benchmarks, constraining long-term benefits, fostering opportunities for corruption, and presenting various implementation challenges; thus, a structured educational plan is recommended to mitigate these drawbacks. Stakeholder collaborations provide checks for mining firms to regularly assess their relationship and comply with the LCP to ensure peace.

Stakeholders Theory. The concept of the stakeholders' theory seeks to ensure that firms meet the interests of all stakeholders, including customers, shareholders, employees, and the community. Given the rise in sustainability pressures from customers and civil society perspectives, mining firms must ensure their operations are environmentally responsive to ensure safe fauna and flora. Additionally, the shareholders benefit from responsible profits, and the community's interest in local community development must be strategically incorporated.

The continual critique of the poor development in mining communities and rustic lifestyle has influenced community leaders to demand increased benefits from the mining lease, culminating especially in a 10% royalty demand instead of the former 1%, with other government demands. Additionally, community leaders suggest community management of the funds instead of the government, due to mistrust and bureaucracy in releasing funds for community amenities. Astute researchers have posited that the non-utilisation of mining revenue in communities has further widened the poverty gap, already grappling with employment issues. Community members, unlike community artisanal mining, where the inhabitants are economically empowered, and all funds generated are used in the community. This has been affirmed by other researchers, stating that artisanal and formal miners augment household expenditure, but only artisanal mining substantially mitigates poverty (Olurotimi et al., 2024).

For the improved community's benefit, firms directly involved in mining should employ about two-thirds of the community inhabitants to ensure economic empowerment either directly or indirectly (Jackson et al., 2023). Latent research shows that Corporate Social Responsibility (CSR) influence could ensure community development; conversely, critics contend that CSR methods never fulfil these objectives but reduce developmental advantages for local populations affected by the extraction of natural resources (Slack 2012; Frederiksen 2018). Comparatively, whilst the largest lithium mining employs about 5,000 people, the largest lithium battery manufacturing company employs over 30,000 people (Garbis et al., 2024; Vasilauskas et al., 2024). This further shows how mining communities are deprived of the benefits of industrialisation while other cities largely benefit from

their resources, leaving them with environmental and economic predicaments. As such there is the need for companies to generate real benefits for their operating communities throughout their value chains by offering employment opportunities, providing educational opportunities for employees, developing physical infrastructure, transferring technology, remitting taxes, or improving access to essential products and services, including food, healthcare, and energy, to gain and sustain their social license to operate (Kourouma, 2023).

The study further seeks to chronicle the impacts of inefficiencies in using extractive natural resources, leaders' lack of strategic sustainable orientation, and the future economic repercussions on the community, especially raising disaffection about mining exploration. While some have propounded that mineral resources are a curse rather than a blessing, others hold a different view (Khan et al., 2023). The continual misuse of these mineral resources has created insecurities (Kyem, 2021). Quasi-local indigenes mining firms called Galamsey on most of the company-acquired concessions, created conflicts and bred armed groups in these localities, which, if not well managed, could result in emerging terrorism.

The rapid exploitation of these resources without sustainable measures and strategies has created a vacuum yet to be filled (Li & Huang, 2023). In reducing these conflicts, most companies have instituted community-based development management groups to channel part of their resources directly through these groups to resolve community problems (Nambisan & George, 2024). The challenge is whether these efforts meet the local youth and community's demands. In effect, this research reflects a leader's strategic sustainable orientation on extracting and using natural resources and its impact on community development. Governments of resource-rich nations should exhibit remarkable proficiency, expertise, and adaptability in managing all facets of natural resource production. (Algharabali & Al-Thaqeb, 2023). The existing mining policies have neglected the socio-economic impacts on community livelihood and suggested oblique strategies to ameliorate economic effects with some community amenities (Sam et al., 2024; Agyabeng et al., 2024).

Juxtaposing the reality of economic repercussions, including the high cost of living, increasing migration, food insecurity due to reduced land size used for farming, and economic multiplicity, such as low per capita income. Additionally, the absence of economic livelihood has reoriented the youth to engage in small-scale illegal mining, an act of lawlessness, affecting the peaceful community life. Their activities have also impacted negatively on water safety for aquatic life, and unlike previously, when the local inhabitants depended on natural resources for farming, fishing, and timber products, the transition into a natural resource concessionary has altered these narratives (Wirawan et al., 2024). Additionally, the operations of these mining companies have destroyed many of the water bodies that serve as drinking and fishing sources

for the community. In other areas, groundwater quality has been equally compromised due to the seepage of toxic chemicals, impacting the health of the people in the community. Regarding forest resources, mining has resulted in deforestation, depriving them of Timber, and declaring some arable lands arid. This study seeks to reorient the socio-economic effects of mining on these communities and whether the output of mining ensures environmental equilibrium.

These have reverberated the rhetoric that the previous effects of mining on communities could be repetitive in these new mining concession areas. This study aims to review the economic impact of mining and natural resource extraction on community development, the essence of strategic sustainable orientation policy guiding mining operations in these communities, and the social impacts of mining firms on livelihood and resource use efficiency. This study will leverage the contributions from the local content policy (LCP) and triple bottom line theory (TBL) to buttress the arguments.

Previous studies by Dikgwatlhe & Mulenga (2023) uncovered misconceptions and misunderstood expectations regarding agreements between mining companies and the government's authority over the community. Local municipal councils are advised to foster entrepreneurship, provide financial aid and investment within the community, and build small and medium-sized firms for the informal business sector, which predominantly employs unskilled labor. However, most of these firms are more concerned about providing some social amenities to the neglect of economic investment ventures (Hilson et al. 2024), especially in developing countries. There are still unresolved arguments about the contribution of mining to community development, whilst some have argued about the positive economic impact of mining on community development, especially in developed countries, others continually assert that mining is a curse rather than a blessing. Projecting on this, a study by Shiquan et al. (2022) in China indicated that mining has decreased the income of the nearby inhabitants by 18.5% and their health by 13.6%. Moreover, it was stated that the poor groups suffer even more compared to the regular community members. It has also been mentioned that mining leads to a community inequality of 1.7% increase. The poverty incidence of neighboring communities to mining operations is much higher, specifically, there is a 33.9% hike in this regard. The impact of mineral extraction industries differs across locations because of the differences in landscape, culture, and economy. Onifade et al. (2024) projected that the upcoming studies will emphasize social, economic, and ecological aspects, and thus, the application of green mining technologies will be better understood when all these factors come together. This, however, is not the case with some who are expressing concern over unkept promises, environmental neglect, and lack of economic support, which would have otherwise been positive influences of mining companies on the livelihood of communities, leading to a rise of illegal small-scale mining activities demanding better eco-

nomical pacification, a rise in community violence, and the emergence of armed groups. Muhirwa et al. (2023) clearly point out that most of the studies that associate extractive industries and sustainable development in rural Africa have been centered around artisanal and small-scale mining, and the activities of the major mining companies have not been considered much. As for the strategic sustainable development of mining, the researchers Onifade et al. (2024) indicate that the full and active adoption of green mining technology results in a drastic reduction of CO₂ emissions, besides being less energy-consuming and having a better waste management system than the conventional mining methods, and on top of it, the mining communities experience economic efficiency. Collaboration, policy coherence, sustainable investment, and diversification of rural economic resources are suggested to connect extractive sector stakeholders with the sustainable development of adjacent rural communities. Muhirwa et al. (2023) advocate for additional research to investigate the transformative techniques essential for mining investment and to formulate advantageous policies that assist communities residing in mining regions during and after the cessation of mining activities.

Relationship between socioeconomic measures and community satisfaction

The affiliation between socioeconomic status and the community satisfaction index has been described by several researchers as complementary (Hannscott, 2016). While socioeconomic factors improve individual members' satisfaction level, especially access to a job and living income, and educational background, some indicators do not affect the satisfaction level.

Figure 1: Conceptual framework

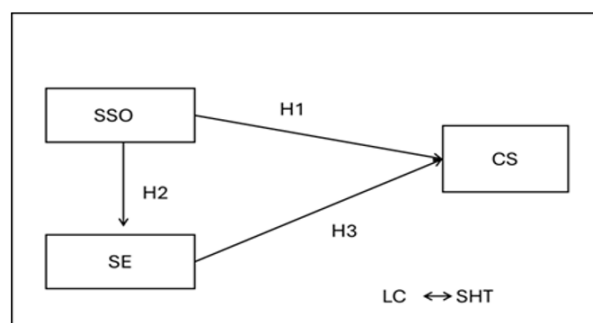

Note: SSO – Strategic sustainability orientation; SE – Socioeconomics; CS – Community Satisfaction; LC – Local Content; SHT – Stakeholders Theory. Source: own research.

The interrelations between LCP theory and stakeholder theory are cyclical, influencing community decisions and government policy in various communities. The theory proposes that mining firms should improve the local economy by outsourcing supply contracts to community inhabitants, ensuring economic empowerment of the catchment area through internal trade. However, mining firms disregard this, attributing it to the lack of competitiveness and the financial resources to provide these services. This study seeks to propose the stakeholder theory to support the actualization of theory through stake-

holder engagement (Government, community leaders, civil society organisations and firm management). There should be a cyclical relationship in enforcing sustainable orientation and socioeconomic practices to influence community satisfaction. This study outlines the theoretical effect and measurable decisions for community engagement and understanding in appraising the long-term impacts of mining investment as captured in Figure 1.

Measurement indicators

Several measures and determinants have been utilised to measure strategic sustainable orientation, socioeconomic indicators and community development. According to the World Bank, sustainable orientation could be defined in relation to the five P’S, which include Peace, planet, prosperity, people and partnerships, whilst community development has been determined using social, economic and environmental determinants. Where planets factor in environmental factors, peace is the security index of the community. This study relies on data from the World Bank to measure sustainable orientation (CO2, forest areas, renewable index, HDI, and gender) while the measurement of socio-economic impacts includes unemployment rate, poverty, peace and migration (see table 1).

Some studies have relied on questionnaire data to assess the sustainable strategic impact previously; our study seeks to replicate this method using a questionnaire developed from the verified measures of the variables. As such, our objective is to use these data to evaluate the trends in parameters related to the mining impacts on socioeconomic and sustainable-oriented measures of community development in Ghana. Prompting an informed decision about mining negotiations. Our study relied on 232 responses from mining-affected communities in the Ashanti region, selected based on the level of devastation on community livelihood. The communities were selected using purposive sampling based on the regions' contributions and richness in minerals to Ghana economy. Participants were community leaders, assemblymen, unit committee leaders, and some indigenous people living in the community.

Sampling procedure

A purposive sampling procedure was selected since it was efficient, easy and affordable and had easily available subjects, given that the main objective of this research is to investigate community satisfaction using the sustainable orientation and the socio-economic factors' impacts on mining in Ghana. This study relied on a prior

Table 1: Measurement indicators

Strategic sustainability orientation (SSO)	Leadership connecting with the organization and ensuring resource use efficiency.	(Kohli, A. K., Jaworski, B. J., & Kumar, A., 1993); (Dess, G. G., & Lumpkin, G. T., 2005);	The five-point Likert scale is from strongly disagree to agree. (SD -SA)
Socioeconomic (SE)	Economics Social and environmental factors	Wealth Index	ZSA et al., 2019
Community satisfaction (CS)	Education, Marital status, Health status, Income level, Employment status, Household size, Religion, Age, Government services, Poverty status.	Quality-of-life indicator used by the Lancashire QoL Profile (LQOLP).	Hansson, L., Svensson, B., & Björkman, T. (1998). Quality of life of the mentally ill. Reliability of the Swedish version of the Lancashire Quality of Life Profile. <i>European Psychiatry</i> , 13(5), 231-234.

Source: own research

RESEARCH OBJECTIVE, METHODOLOGY AND DATA

Data collection was carried out using a structured online The article aims to investigate the impact of strategic sustainable orientation and socio-economic factors on community satisfaction with mining in Ghana.

Research design

This study employs a quantitative approach, using World Bank time-series data from 2017 to 2023 to measure sustainable orientation and socioeconomic impacts on community development, as established in the conceptual framework.

established Likert scale indicated in the measurement construct table 1. Information was gathered using a semi-structured questionnaire with anonymous responses. Because questionnaires are a cheap approach to collecting data from a potentially large number of respondents, this form of data gathering was chosen. The anonymity and confidentiality protections of the questionnaires were set up.

The advantages of the questionnaires are considerable, but there are some limitations as well. Surveys' being standardized does not allow for easy clarification of details in questions, which might be misunderstood by the respondents (Cohen et al., 2011). The use of closed-ended and Likert-scale items in the semi-structured que-

Table 2: Items definition

Items	Measures questions	Likert Scale
Sustainable orientation (sso)	<ol style="list-style-type: none"> 1. Leaders have introduced innovations in the firm. 2. Environmentally friendly materials are used in operations to promote sustainable resource use. 3. We have broad systems decisions involving all employee contributions 4. My firm, Sustainable Development, ensures that we act responsibly towards our stakeholders(customers, employees, and regulators) 	1-5 Likert scale (Strongly Disagree-strongly Agree)
Community satisfaction (CS)	<ol style="list-style-type: none"> 1.The majority of its citizens have attained the minimum educational level in the community. 2. Most community members can afford the basic cost of Health. 3. The majority of the employable population is employed either in mining or farming. 4. The majority of the community members have not migrated out of the community. 5. Mining firms and the government provide basic social infrastructure to make a happy community living. 	1-5 Likert scale (Strongly Disagree-5 strongly Agree)
Socioeconomic (SE)	<ol style="list-style-type: none"> 1. The gender imbalance favours women and children 2. Has mining impacted your social life in the community 3. There is a higher price index for food in the community. 4. Women have the right to own property in the community. 5. Mining activity has improved farming in the area, increasing farmers' farm size significantly. 6. There is a poverty level in the community. 7. Households' wealth is ranked by asset ownership. 8. The community has a portable water source and clean river bodies 9. Community members have an income level that meets the basic needs of life. 10. The community still maintains a forest reserve and tree protection of the river bodies. 11. Mining firms comply with the environmental protection policy of the land and water bodies. 	1-5 Likert scale (Strongly Disagree-5 Strongly Agree)

Source: own research

stionnaire allowed for quick responses with almost no writing involved. The complete questionnaire contained 52 items.

Questionnaire and statements formulation

The questionnaire was constructed of demographic characteristics of the respondents (age, education, experience, and position within the company – 4 questions in total). The second part of the questionnaire consisted of statements related to individual factors: Sustainable Orientation (SSO – 4 items), Community Satisfaction (CS – 5 items), and Socioeconomic factors (SE – 11 items). The questionnaire primarily contained closed-ended questions with a single-choice format (5-point Likert scale). A control question was also included. Respondents provided their consent for the use of their answers for scientific purposes.

The following Table 2 presents the items that were the subject of the questionnaire survey.

Formulation of hypotheses

To evaluate the objective of the article, the following partial hypotheses were formulated:

- H1: Mining operations' impact on the economic livelihood of the community.
- H2: The social and economic impacts of mining ensure improved income for the local indigenous, but also food insecurity.
- H3: Strategic Sustainable orientation of leaders ensures mining firms' adherence to environmental policies and practices.
- H4: Community satisfaction has a positive impact on mining firms' sustainability operations.

Factor analysis and partial least squares structural equation modeling (PLS-SEM) constitute the "gold standard" in contemporary socio-psychological research. Their main importance lies in their ability to measure phenomena that are not directly observable (so-called latent constructs). The following statistical methods were used in data analysis:

Confirmatory factor analysis (CFA), which verified whether our data really fit the theoretical model. In this context, the validity (Cronbach's alpha, VIF) and reliability

ty (Composite reliability, Average variance extracted) of the factor statements were also tested (see Table 4).

PLS-SEM can work with factors (SSO, CS, SE) that we do not see directly (e.g. corporate culture), but which are represented by the responses in the questionnaire. Unlike classical regression, PLS-SEM can test the entire network of relationships at once - including direct effects, mediation (when one factor affects another through a third) and moderation (when the relationship depends on another variable, e.g. gender). PLS-SEM is extremely popular because it does not have such strict requirements for normal data distribution and it is sufficient for a relatively smaller sample of respondents compared to CB-SEM (Covariance-Based SEM, e.g. see Table 7).

Structure of respondents

This outlines the population from which responses were obtained for the analysis (see Tab. 3).

Table 3: Demographic characteristics of respondents

Demographic indicators		Abs. (n)	Relative (%)
Gender	Male	95	40.95
	Female	137	59.05
Education	Secondary School	117	50.43
	Diploma	30	12.93
	Bachelor	22	9.49
	Masters	63	27.15
Experience	1-5 years	56	24.14
	6-10 years	37	15.96
	11-15years	52	22.41
	16-20 years	62	26.72
	Above 20 years	25	10.77
Employment	Unemployed	20	8.62
	Farmers	115	49.57
	Private firms	80	34.48
	Government	17	7.33

Source: own research

This descriptive analysis outcome, as indicated in Table 3, shows that female respondents dominate the sample community indigenes and are the most affected, given their support role in the family, with many being single mothers; they make up 59.05% of the respondents. Additionally, as for Education wise, most community respondents were secondary school leavers with a percentage of 50.43%. Based on experience, most of the respondents were farmers with numerous years of experience, and others were government-employed and private firm officers with a salary range of between 100-300 (\$). The other categories are people who have had a primary education or never been educated.

RESULTS

The following Table (see Table 4) presents the empirical results of the verification of the reliability and validity of items in the questionnaire.

The CR values in Table 4 varied from 0.791 to 0.877, all exceeding the 0.70 threshold, indicating strong reliability across constructs (Hair et al., 2019). On Collinearity checks using the VIF, our values from Table 4 indicate that they are below the threshold of 3.30 suggested, so there are no issues of collinearity.

Furthermore, the average variance extracted (AVE) ranged from 0.545 to 0.665, surpassing the threshold of 0.50 and affirming the constructs' convergent validity. We confirmed discriminant validity by dwelling on the Fornell and Larcker (1981) criterion, in which the square root of AVE for each construct was more than the inner correlation of its corresponding variable.

The construct correlation is observed by assessing discriminant validity using the hetero-trait-monotrait (HTMT) in Table 5, which is preferred. It has been suggested that HTMT disattenuated the estimated correlation between measures. This measure is more effective and accurate than the Fornell-Lacker criterion in confirming discriminant validity. As recommended, the HTMT threshold should be below 0.90 or 0.85, depending on the study context.

Table 5: Heterotrait-monotrait ratio (HTMT) – Matrix

HTMT	CS	SE	SSO
CS	1	0.594	0.597
SE	0.594	1	0.896
SSO	0.597	0.896	1

Note: SSO – Strategic sustainability orientation; SE – Socioeconomics; CS – Community Satisfaction.

Source: own research

The results (see Table 5) confirmed the discriminant validity of the questionnaire. The HTMT values are well below the strict threshold of 0.90. This demonstrates that the investigated constructs (e.g. HTMT between CS vs. SE = 0.594, HTMT between CS vs. SSO = 0.597) are clearly and statistically distinguishable from each other. The findings can be interpreted that the respondents in the questionnaire perceived these factors as different concepts and did not mix them.

The following Table (see Table 6) presents the empirical results of the verification of the Fornell-Larcker criterion of factors (CS, SE, SSO) in the questionnaire.

The reported results in 5 and 6 align with the threshold guidelines, indicating that the correlation between measurement variables meets the discriminant validity criteria. Lastly, we evaluated the model fit using R-squared values of 0.3 for CS and 0.618 for SSO, which indicate

Table 4: Verification of validity and reliability of questions

Factors/Items	Cronbach's alpha	Composite reliability (rho_a)	Composite reliability (rho_c)	Average variance extracted (AVE)	VIF
SSO	0.722	0.791	0.781	0.545	
SS02	0.725				1.40
SS03	0.837				1.12
SS04	0.641				1.35
SE	0.867	0.877	0.897	0.556	
SE1	0.712				2.09
SE2	0.681				2.21
SE3	0.757				2.22
SE5	0.822				2.16
SE7	0.689				1.70
SE8	0.828				2.39
SE9	0.717				1.85
CS	0.831	0.831	0.888	0.665	
CS1	0.737				1.34
CS2	0.854				2.80
CS3	0.871				2.89
CS4	0.793				1.73

Note: SSO – Strategic sustainability orientation; SE – Socioeconomics; CS – Community Satisfaction. Source: own research

Table 6: Fornell-Larcker criterion

	CS	SE	SSO
CS	0.840		
SE	0.570	0.755	
SSO	0.522	0.792	0.737

Note: SSO – Strategic sustainability orientation; SE – Socioeconomics; CS – Community Satisfaction.

Source: own research

Table 7: Verification of hypotheses

H	Path	Original sample (O)	Sample Mean (M)	Std. deviation (STDEV)	T statistics (O/STDEV)	P value	Decision
H1	SSO -> CS	0.259	0.259	0.079	3.273	0.001	Supported
H2	SE -> SSO	0.786	0.790	0.022	35.110	0.000	Supported
H3	SE -> CS	0.321	0.325	0.085	3.782	0.000	Supported

Source: own research

the degree to which the independent variable explains the dependent variable.

The following Table (see Table 7) presents the empirical results of the verification of hypotheses (H1, ..., H3).

The results presented in Table 7 on the path analysis suggest that the SSO have positive affiliation with community satisfaction in H1, with significant effects if well implemented. Additionally, the H2 relationship between socioeconomic factors and strategic sustainable orienta-

tion was significant. The findings demonstrate that improved socioeconomic factors help improve sustainable practices in mining communities. Furthermore, socioeconomic factors have substantial effects on community satisfaction in the hypothesis three analysis. Hypotheses H1, H2, and H3 were supported. P-values are less than level of significance.

The mediating effects between SE, SSO and CS are

present and verified in the table 8.

Table 8 outlines the mediating effect of socioeconomic factors on sustainable orientation and community satisfaction, indicating a partial mediation effect of SSO*SE->CS (H4). The findings demonstrated that green innovation partially mediated the variables. This suggests that resources should be invested directly to support socioeconomic improvement and enhance community satisfaction. Hypotheses H4 was supported.

Table 8: Mediating effects

H	Path coefficient	O	M	Standard deviation (STDEV)	T statistics (O/STDEV)	P values	Decision
H4	SE -> SSO -> CS	0.204	0.205	0.063	3.256	0.001	Supported

Note: H – Hypothesis, O – Original sample, M – Sample mean.

Source: own research

The resulting model of relationships between factors and items, realized using the PLS-SEM approach, is presented in Figure 2.

Second, improved socio-economic livelihoods are positively associated with the adoption of strategic sustainability ideas, as economic empowerment enables communi-

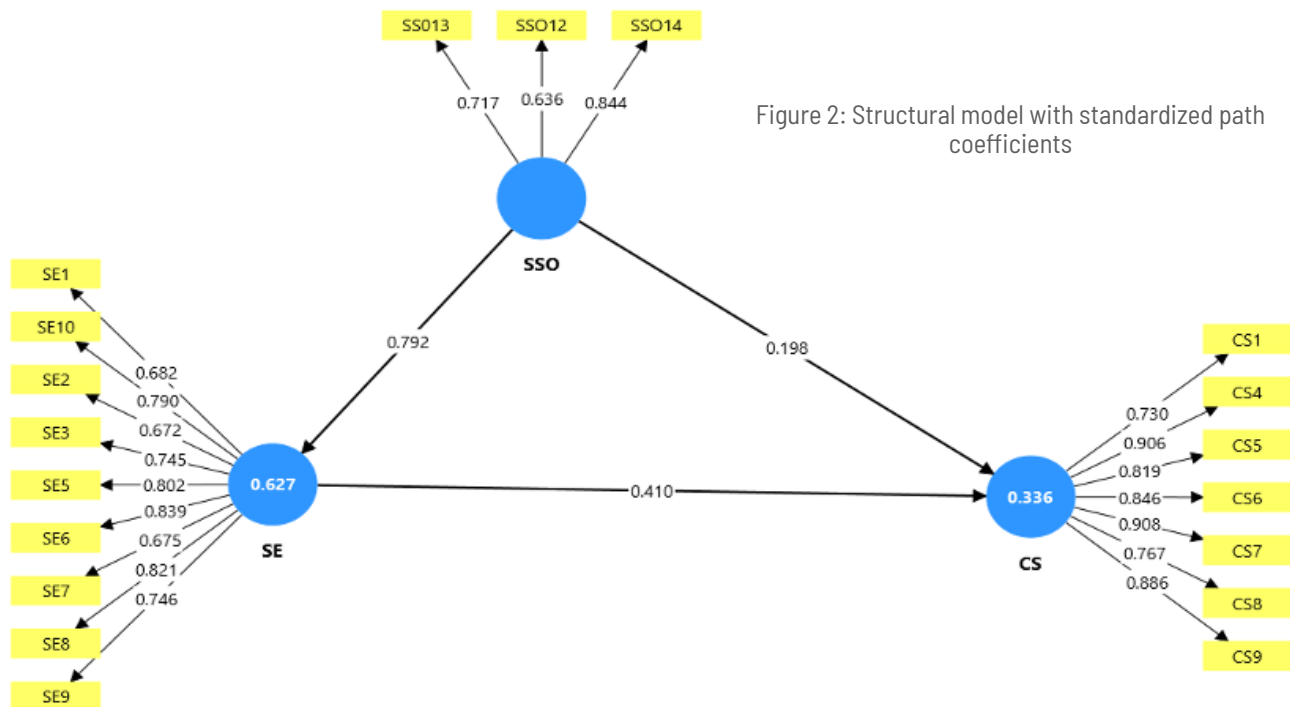

The structural model (path model; see Figure 2) was developed in SmartPLS. The values on the arrows between the latent variables represent the strength of the direct effects: (i) the relationship between SSO and SE (path coefficient = 0.792), indicating a very strong positive relationship. Strategic sustainable orientation (SSO) significantly predicts socio-economic factors (SE). (ii) The relationship between SE and CS (path coefficient = 0.410) indicates that socio-economic factors have a moderately strong positive effect on community satisfaction (CS). (iii) The relationship between SSO and CS (path coefficient = 0.198) shows a weaker direct effect of sustainable orientation on satisfaction. This suggests that SSO influences community satisfaction (CS) primarily indirectly through SE (i.e., mediation).

DISCUSSION

Prior studies have recommended corporate social responsibility (CSR) as a tool for addressing socio-economic imbalances associated with mining operations and community development. However, much of this work has prioritised environmental issues at the expense of community-level socio-economic inequities (Haroon & Hayyat, 2025). The results indicate that, given the affected communities' pre-existing sustainability orientation—shaped in part by farming-based livelihoods—sustainability-oriented policies substantially influence community satisfaction when implemented by firms. Accordingly, mining companies should adopt measures that compensate for ecological losses through meaningful and sustainable economic initiatives that support alternative livelihoods.

ty members to engage in, and identify with, sustainability-oriented practices. This empowerment can support alternative agribusiness activities and strengthen livelihoods; conversely, when residents perceive economic neglect, they may pursue informal or illegal means to compete with firms, including theft of company resources.

Third, aligning socio-economic policies with community needs significantly enhances community satisfaction and supports improvements in human development outcomes. While earlier studies argued that socio-economic policies promote human development, our findings further suggest that such policies directly strengthen community satisfaction and local development (Fried, 1984). In communities where firms invest in socio-economic initiatives, sustainability awareness and learning improve markedly. Prior research has also suggested that social investment decision-analytic tools should be designed to reflect local conditions. In this context, socio-economic gains appear to encourage community members to participate more actively in environmental protection and in safeguarding mining operations, reflecting a perceived alignment of interests and benefits.

Finally, the findings suggest that integrating community sustainability concerns into socio-economic policies increases satisfaction with mining firms' operations over the long term.

CONCLUSION

This paper addresses a critical research gap by examining the effects of strategic sustainable orientation and socio-economic factors on community satisfaction with

mining activities in Ghana. The primary objective was to identify key contributors to the heightened demand for improved mining operations, local development, and economic empowerment, given the persistent limitations of existing regulatory approaches in delivering benefits to host communities. The findings indicate that mining operations should not be evaluated solely on economic grounds; rather, firms' sustainability-oriented policies, together with their long-term socio-economic impacts on host communities, should be assessed to inform decisions that support local development and livelihoods. Greater community satisfaction can strengthen relations and transparency between mining firms and communities, thereby reducing incentives for illegal mining.

In addition, rather than relying primarily on voluntary CSR programmes, local community development plans should be submitted alongside environmental and social impact assessments to support strategic decision-making and regulatory oversight. The practical implications are substantial: community-level assessments can provide a more direct evaluation of mining contributions to livelihoods than reliance on government reporting alone, which may be incomplete. The study further suggests that future mining firms should include community development assessment plans—covering both socio-economic and sustainability benefits—as part of regulatory compliance documentation. Moreover, a tripartite assessment committee involving government, firms, and community representatives should be established to review firms' obligations and evaluate implementation.

Overall, the study provides managerial and practical insights for the mining industry. The central conclusion is that strategic sustainable orientation and sustained attention to socio-economic outcomes are key drivers of co-

munity satisfaction and should be embedded in mining operations. Improved community development can also enhance national economic value through stronger food security and more responsible mining practices.

This study is limited by the inability to collect views from all members of the affected communities; therefore, the findings may not fully represent all perspectives. In addition, the study could not examine the full range of socio-economic factors, and future research should consider longitudinal designs to assess impacts over time.

Future research directions include comparative international analyses. Studies could compare countries with different levels of economic development (e.g., V4 countries versus Scandinavian countries) to examine whether cultural and regulatory environments moderate the relationships in the model. The authors also plan to supplement this research with qualitative in-depth interviews with employees to better explain why socio-economic factors (SE) so strongly influence sustainable orientation (SSO). Finally, given the emergence of Industry 5.0 and its emphasis on people and sustainability, future research could examine how artificial intelligence (AI) and digitalisation shape employees' socio-economic status and their perceptions of sustainability.

ACKNOWLEDGEMENT

The authors acknowledge the financial support from IGA/FAME/001/2025. We also appreciate Tomas Bata University, Zlin, for providing research facilities and assoc. prof. Jan Dvorsky for their valuable assistance with manuscript proofreading.

Copyright © authors. Published by European Center for Economic & Social Research under the [Creative Commons Attribution \(CC BY 4.0\) license](#). Anyone may reproduce, distribute, translate and create derivative works of this article (for both commercial and non-commercial purposes), subject to full attribution to the original publication and authors.

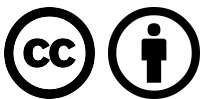

AUTHOR CONTRIBUTIONS STATEMENT

Conceptualisation, C.R.A. and methodology, S.A. and C.R.A.; software, S.A; validation, CRA.; formal analysis, CR.A; investigation, S.A. and C.R.A resources, M.A.; data curation, CRA.; writing-original draft preparation, S.A and M.A; writing-review and editing, M.A.; visualisation, and supervision. All authors have read and agreed to the published version of the manuscript.

DATA AVAILABILITY STATEMENT

The datasets used and analysed during the current study are available from the corresponding author upon reasonable request.

CONFLICTS OF INTEREST

The authors declare no conflicts of interest. The funders had no role in the design of the study; in the collection, analyses, or interpretation of data; in the writing of the manuscript; or in the decision to publish the results.

REFERENCES

1. Adusei, S., Arthur, E. K., Gikunoo, E., Amponsah, W., Agyemang, F. O., & Ohemeng-Boahen, G. (2025). Heavy Metal Pollution From Illegal Mining 'Galamsey' Activities on the Viability of *Clarias gariepinus* in the Oda River, Ghana. *Aquaculture, Fish and Fisherssies*, 5(3), e70076. <https://doi.org/10.1002/aff2.70076>
2. Agyabeng, A. N., Bawole, J. N., Ahenkan, A., Mensah, J. K., & Preko, A. (2024). External stakeholders in the governance of slums in Ghana. *Social Responsibility Journal*, 20(3), 427-443. <https://doi.org/10.1108/SRJ-06-2022-0253>
3. Akuaake, I. (2024). *Assessing resource curse risks in Namibia's green hydrogen developments with insights from diamond mining*. University of Cape Town, Faculty of Engineering and the Built Environment. <http://hdl.handle.net/11427/40748>
4. Algharabali, B. G., & Al-Thaqeb, S. A. (2023). the natural resource curse: is it really a curse? *International Journal of Energy Economics and Policy*, 13(4), 237-245. <https://doi.org/10.32479/ijeep.14300>
5. Asuamah Yeboah, S. (2023). Digging deeper: The impact of illegal mining on economic growth and development in Ghana. *Minch Personal RePEc Archive*. <https://doi.org/10.13140/RG.2.2.12212.83845>
6. Ayambire, R. A., Nunbogu, A. M., Cobbinah, P. B., Kansanga, M. M., Pittman, J., & Dogoli, M. A. (2024). Constructing alternative interpretation: Embeddedness of illegality in small-scale mining. *The Extractive Industries and Society*, 17, 101430. <https://doi.org/10.1016/j.exis.2024.101430>
7. Bansah, K. J., Acquah, P. J., & Assan, E. (2022). Guns and fires: The use of military force to eradicate informal mining. *The Extractive Industries and Society*, 11, 101139. <https://doi.org/10.1016/j.exis.2022.101139>
8. Bjornlund, V., Bjornlund, H., & van Rooyen, A. (2022). Why food insecurity persists in sub-Saharan Africa: A review of existing evidence. *Food Security*, 14(4), 845-864. <https://doi.org/10.1007/s12571-022-01256-1>
9. Blanco, G. D., Fernández-Llamazares, Á., Blanco, G. D., Baker, J., Tagliari, M. S. M., Hayata, M. A., ... & Hanazaki, N. (2023). The impacts of mining on the food sovereignty and security of Indigenous Peoples and local communities: A global review. *Science of the Total Environment*, 855, 158803. <https://doi.org/10.1016/j.scitotenv.2022.158803>
10. Boateng, F., Wisdom, G. E., & Atiku, S. O. (2025). A time series analysis of mineral revenue and economic growth in Ghana. *Cogent Economics & Finance*, 13(1). <https://doi.org/10.1080/23322039.2025.2465986>
11. Coulibaly, M., Foltz, J., Parker, D., Olurotimi, O., & Traoré, N. (2024). The effects of mining on local poverty in developing countries: Evidence from Mali. *World Development*, 180, 106605. <https://doi.org/10.1016/j.worlddev.2024.106605>
12. Dawar, G., & Singh, S. (2023). Barriers to corporate social responsibility implementation in the medium-sized manufacturing sector: an interpretive structure modelling approach. *Journal of Entrepreneurship in Emerging Economies*, 15(2), 447-479. <https://doi.org/10.1108/JEEE-12-2020-0451>
13. Dikgwatlhe, P., & Mulenga, F. (2023). Perceptions of local communities regarding the impacts of mining on employment and economic activities in South Africa. *Resources Policy*, 80, 103138. <https://doi.org/10.1016/j.resourpol.2022.103138>
14. Dowling, C., & Otero, G. (2025). Mirages or miracles? Lithium extraction and the just energy transition. *Energy Research & Social Science*, 119, 103862. <https://doi.org/10.1016/j.erss.2024.103862>
15. Garbis, Z., Heleniak, T., Poelzer, G., Söderberg, C., & Orttung, R. (2024). "The ketchup effect": Challenges in reconciling growth and justice in Northern Sweden's green transition. *Energy Research & Social Science*, 112, 103537. <https://doi.org/10.1016/j.erss.2024.103537>
16. Hannscoff, L. (2016). Individual and contextual socioeconomic status and community satisfaction. *Urban Studies*, 53(8), 1727-1744. <https://doi.org/10.1177/0042098015574811>
17. Haroon, M., & Hayyat, M. (2025). Assessing the dual impact of gold mining on local communities: Socio-economic benefits and environmental challenges. *Resources Policy*, 103, 105559. <https://doi.org/10.1016/j.resourpol.2025.105559>
18. Hilson, G., Hu, Y., Hilson, A., Owen, J. R., Lèbre, É., & Sauerwein, T. (2024). Rethinking resource enclivity in developing countries: Embedding Global Production Networks in gold mining regions. *Journal of Economic Geography*, 24(1), 95-116. <https://doi.org/10.1093/jeg/lbad028>
19. Jackson, S., Poelzer, G., Poelzer, G., & Noble, B. (2023). Mining and sustainability in the circumpolar North: the role of government in advancing corporate social responsibility. *Environmental Management*, 72(1), 37-52. <https://doi.org/10.1007/s00267-022-01680-1>
20. Kaksonen, A. H., & Petersen, J. (2022). The Future of Biomining: Towards Sustainability in a Metal-Demanding World. In *Biomining Technologies. In Extracting and Recovering Metals from Ores and Wastes* (pp. 295-314). Chem: Springer International Publishing. https://doi.org/10.1007/978-3-031-05382-5_17
21. Khan, Z., Hossain, M. R., Badeeb, R. A., & Zhang, C. (2023). Aggregate and disaggregate impact of natural resources on economic performance: role of green growth and human capital. *Resources Policy*, 80, 103103. <https://doi.org/10.1016/j.resourpol.2022.103103>
22. Kourouma, J. M. (2023). Community-centred approach for assessing social sustainability in mining regions: A case study of Chingola district, Zambia. *Sustainable Development*, 31(4), 3102-3127. <https://doi.org/10.1002/sd.2572>

23. Kourouma, J. M., Monde, C., Phiri, D., & Syampungani, S. (2023). Community-centred approach for assessing social sustainability in mining regions: a case study of Chingola district, Zambia. *Sustainable Development*, 31(4), 3102-3127. <https://doi.org/10.1002/sd.2572>
24. Kulkarni, V., & Aggarwal, A. (2024). Business response to mandatory corporate social responsibility with evidence from India. *Business Strategy & Development*, 7(1), e323. <https://doi.org/10.1002/bsd2.323>
25. Kwakwa, P. A., Adzawla, W., Alhassan, H., & Achaamah, A. (2022). Natural resources and economic growth: Does political regime matter for Tunisia? *Journal of Public Affairs*, 22, e2707. <https://doi.org/10.1002/pa.2707>
26. Kyem, P. A. (2021). Managing natural resource conflicts with participatory mapping and PGIS applications. Switzerland: Springer. <https://doi.org/10.1007/978-3-030-74166-2>
27. Li, W., Li, W., Seppänen, V., & Koivumäki, T. (2023). Effects of greenwashing on financial performance: Moderation through local environmental regulation and media coverage. *Business strategy and the environment*, 32(1), 820-841. <https://doi.org/10.1002/bse.3177>
28. Li, Y., & Huang, Y. (2023). Enhancing resources efficiency: Studying economic development in resource-rich regions for long-term sustainability of China. *Resources Policy*, 86, 104234. <https://doi.org/10.1016/j.resourpol.2023.104234>
29. Muhirwa, F., Shen, L., Elshkaki, A., Hirwa, H., Umuziranenge, G., & Velepini, K. (2023). Linking large extractive industries to sustainable development of rural communities at mining sites in Africa: Challenges and pathways. *Resources Policy*, 81, 103322. <https://doi.org/10.1016/j.resourpol.2023.103322>
30. Nambisan, S., & George, G. (2024). Digital Approaches to Societal Grand Challenges: Toward a Broader Research Agenda on Managing Global-Local Design Tensions. *Information Systems Research*. <https://doi.org/10.1287/isre.2023.0152>
31. Obiri-Yeboah, A., Nyantakyi, E. K., Mohammed, A. R., Yeboah, S. I. I. K., Domfeh, M. K., & Abokyi, E. (2021). Assessing the potential health effects of lead and mercury and the impact of illegal mining activities in the Bonsa River, Tarkwa Nsuaem, Ghana. *Scientific African*, 13, 13, e00876. <https://doi.org/10.1016/j.sciaf.2021.e00876>
32. Olurotimi, O., Foltz, J., Nouhoum, T., Coulibaly, M., & Parker, D. (2024). The Effects of Mining on Local Poverty in Developing Countries: Evidence from Mali. *World Development*. <https://doi.org/10.1016/j.worlddev.2024.106605>
33. Onifade, M., Zvarivadza, T., Adebisi, J. A., Said, K. O., Dayo-Olupona, O., Lawal, A. I., & Khandelwal, M. (2024). Advancing toward sustainability: The emergence of green mining technologies and practices. *Green and Smart Mining Engineering*, 1(2), 157-174. <https://doi.org/10.1016/j.gsme.2024.05.005>
34. Saaka, S. (2022). *Addressing mining sector conflicts in Ghana*. Retrieved from <http://hdl.handle.net/10464/16948>
35. Sam, K., Pegg, S., & Oladejo, A. O. (2024). Mining from the pipeline: artisanal oil refining as a consequence of failed CSR policies in the Niger Delta. *Journal of Environmental Management*, 352, 120038. <https://doi.org/10.1016/j.jenvman.2024.120038>
36. Sefa-Nyarko, C. (2024). The crisis of leadership in minerals governance in Ghana: Could process leadership fill the void? *The Extractive Industries and Society*, 18, 101470. <https://doi.org/10.1016/j.exis.2024.101470>
37. Shiquan, D., Amuakwa-Mensah, F., Deyi, X., Yue, C., & Yue, C. (2022). The impact of mineral resource extraction on communities: how the vulnerable are harmed. *The Extractive Industries and Society*, 10, 101090. <https://doi.org/10.1016/j.exis.2022.101090>
38. Sutrisno, A. D., Lee, C. H., Suhardono, S., & Suryawan, I. W. K. (2024). Evaluating factors influencing community readiness for post-mining environmental development strategies. *Journal of Environmental Management*, 366, 121823. <https://doi.org/10.1016/j.jenvman.2024.121823>
39. Tioluwani, C. T. (2023). Towards a Stakeholder Model for Institutional Voids: Integrating Host Communities in the Corporate Governance of Nigerian Mining Companies. Doctoral dissertation, University of Essex.
40. Upadhyay, R. K. (2025). *Mining, Mineral Beneficiation, and Environment*. In *Geology and Mineral Resources* (pp. 799-858). Singapore: Springer Nature Singapore. https://doi.org/10.1007/978-981-96-0598-9_12
41. Valenzuela, J. R. (2020). Natural resource governance, grievances and conflict. Fachmedien Wiesbaden: Springer.
42. Vasilaukas, E., McCracken, D., & Horrigan, M. (2024). Projecting the Demand for Workers in the Production of Lithium-Ion Batteries in the United States. Michigan: W. E. Upjohn Institute for Employment Research. <https://research.upjohn.org/reports/304>
43. Vivoda, V., Matthews, R., & Andresen, J. (2025). Securing defence critical minerals: Challenges and US strategic responses in an evolving geopolitical landscape. *Comparative Strategy*, 1-35. <https://doi.org/10.1080/01495933.2025.2456427>
44. Wirawan, R., McIntyre-Mills, J. J., Riswanda, R., Widianingsih, I., & Gunawan, I. (2024). Pathways to well-being in Tarumajaya, West Java: Post-COVID 19 supporting better access to the commons through engagement and a critical systemic reflection on stories. *Systems Research and Behavioural Science*, 41(4), 681-704. <https://doi.org/10.1002/sres.2983>
45. Worlanyo, A. S., Alhassan, S. I., & Jiangfeng, L. (2022). The impacts of gold mining on the welfare of local farmers in Asutifi-North District in Ghana: A quantitative and multi-dimensional approach. *Resources Policy*, 75, 102458. <https://doi.org/10.1016/j.resourpol.2021.102458>

46. Yan, J., Işık, C., & Gu, X. (2024). The nexus between natural resource development, trade policy uncertainty, financial technology and poverty in China: Contributing to the realisation of SDG 1. *Resources Policy*, 95, 105154. <https://doi.org/10.1016/j.resourpol.2024.105154>
47. Yu, H., Bansal, P., & Arjaliès, D. L. (2023). International business is contributing to environmental crises. *Journal of International Business Studies*, 54(6), 1151-1169. <https://doi.org/10.1057/s41267-022-00590-y>